

**Datasheet FU.SEN.RSC.001 4-20mA Heterodyne Contact Sensor IP65**  
**S/N 561YYXXXX**

**General description:**

RSC are standalone ultrasound heterodyned current output sensors designed to be used with industrial standard measurement systems (such as PLC, DCS, and DAQ systems). The design is optimized for permanent installations in the most challenging environment. RSC contact sensors are suitable to ultrasound driven lubrication, mechanical monitoring, steam & valve systems, etc. Sensitive to friction, impact and turbulence, RSC deliver analog signals, adjustable in gain and in mode, that are image of the resonant ultrasonic band-pass.



**Features:**

- Static (RMS value/DC coupling) or dynamic (heterodyned signal/AC coupling) output;
- On board amplification stages;
- Built-in analog filters;
- Hardware calibration;
- On board ambient T° measurement (through serial communication);
- Non-volatile memory (used to save configuration and recover sensor state/mode in case of power outage);
- Unique ID for traceability;
- Digital I/O communication for simple use;
- Serial communication for advanced use;

**Top view pinout (IEC 60947-5-2 compliant):**

- 1 = POWER SUPPLY (Brown)
- 2 = OUTPUT CURRENT (White)
- 3 = GROUND (Blue)
- 4 = COMMUNICATION LINE - should be left floating if not used – (Black)

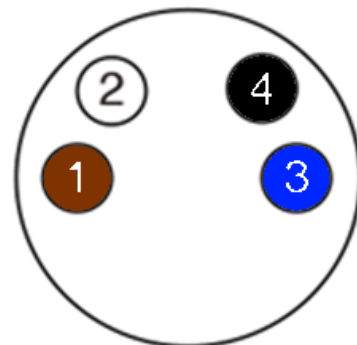

**Technical specifications:**

<b>General specifications</b>	
Dimensions [mm]	
Description	Resonant ultrasound contact sensor with heterodyned output
Type of transducer	Piezoelectric ceramic
Materials	Housing: Stainless steel Connector plate: Aluminum Holster: Nitrile Butadiene Rubber
Weight	126 [Gram] / 4.44 [Oz]
IP rating	IP65
Tests/approvals EMC (Directive 2014/30/EU)	<ul style="list-style-type: none"> <li>• EN 61326-1:2013</li> <li>• EN 55011: 2016 + A1:2017</li> <li>• EN 61000-4-2:2009</li> <li>• EN 61000-4-3:2006 + A1:2008 + IS1:2009 + A2:2010</li> <li>• EN 61000-4-4:2013</li> <li>• EN 61000-4-6:2014</li> <li>• EN 61000-4-8:2010</li> </ul>
<b>Installation</b>	
Power supply	10 [V] to 30 [V]
Maximum consumption	1.2 [W]
Operating temperature	-20 [°C] to +70 [°C]/-4 [°F] to +158 [°F] (see SDT heat sink in section accessories for warmer environments)
Pinout voltage	GROUND to VDD
Recommended maximum cable length	30 [m] / 100 [feet]
Recommended tightening torque	2 [N.m] / 17.7 [lbf.in]
<b>Sensor signal (Typical)</b>	
Resonant frequency	37 [kHz] +/- 1 [kHz]

Gain range	0 [dB] to 60 [dB]
Gain step	12 [dB]
Connector	M8 - 4 pin - Male
<b>Heterodyned signal (Typical)</b>	
Heterodyne frequency	38.5 [kHz] +/- 1 [kHz]
Bandwidth	[0.25 - 4] [kHz], image of the ultrasonic signal
RMS Time Period	1 [s] (static mode only)
Absolute current output range	2 [mA] to 40 [mA] *Adjust the Gain if the current output is not within the optimal output range, depending on your wiring configuration
Full measuring range	~ 32-106 [dB $\mu$ V] (in static mode)
<b>Factory configuration</b>	
Signal mode	Dynamic (sampleable from 10 kHz, referring to your recording instrument/PLC/DAQ)
Gain	60 dB
<b>Optional accessories offered by SDT</b>	
<b>Cables with Straight M8 Connector – PUR RAL7021 -25°C.+90°C IP65 – STRAIGHT SHIELDED</b>	
FU.RSC.CABL.01.015-1	SENSOR-/ACTOR CABLE M8 4PF <> FREE END 1.5m
FU.RSC.CABL.01.030-1	SENSOR-/ACTOR CABLE M8 4PF <> FREE END 3.0m
FU.RSC.CABL.01.050-1	SENSOR-/ACTOR CABLE M8 4PF <> FREE END 5.0m
FU.RSC.CABL.01.100-1	SENSOR-/ACTOR CABLE M8 4PF <> FREE END 10.0m
FU.RSC.CABL.01.200-1	SENSOR-/ACTOR CABLE M8 4PF <> FREE END 20.0m
FU.RSC.CABL.01.XXX-1	SENSOR-/ACTOR CABLE M8 4PF <> FREE END XX.Xm
<b>Cables with 90° M8 Connector – PUR RAL7021 -25°C.+90°C IP65 – STRAIGHT SHIELDED</b>	
FU.RSC.CABL.02.015-1	SENSOR-/ACTOR CABLE M8 4PF 90° <> FREE END 1.5m
FU.RSC.CABL.02.030-1	SENSOR-/ACTOR CABLE M8 4PF 90° <> FREE END 3.0m
FU.RSC.CABL.02.050-1	SENSOR-/ACTOR CABLE M8 4PF 90° <> FREE END 5.0m
FU.RSC.CABL.02.100-1	SENSOR-/ACTOR CABLE M8 4PF 90° <> FREE END 10.0m
FU.RSC.CABL.02.200-1	SENSOR-/ACTOR CABLE M8 4PF 90° <> FREE END 20.0m
FU.RSC.CABL.02.XXX-1	SENSOR-/ACTOR CABLE M8 4PF 90° <> FREE END XX.Xm
<b>Connector to complete assembly</b>	
SICOCA-M8-4MSS-01	CABLE CONNECTOR M8 4PM SHIELDED STRAIGHT A-KEY w/SCREW TERMINAL
SICOCA-M8-4FSS-01	CABLE CONNECTOR M8 4PF SHIELDED STRAIGHT A-KEY w/SCREW TERMINAL
<b>Cables with straight M8 connector 4PM &lt;&gt; M8 4PF – PUR BLACK -25°C.+80°C IP65 – STRAIGHT SHIELDED</b>	
FU.RSC.CABL.05.015-1	SENSOR-/ACTOR CABLE M8 4PM <> M8 4PF 1.5m
FU.RSC.CABL.05.030-1	SENSOR-/ACTOR CABLE M8 4PM <> M8 4PF 3.0m

FU.RSC.CABL.05.050-1	SENSOR-/ACTOR CABLE M8 4PM <> M8 4PF 5.0m
FU.RSC.CABL.05.100-1	SENSOR-/ACTOR CABLE M8 4PM <> M8 4PF 10m
FU.RSC.CABL.05.200-1	SENSOR-/ACTOR CABLE M8 4PM <> M8 4PF 20m
FU.RSC.CABL.05.XXX-1	SENSOR-/ACTOR CABLE M8 4PM <> M8 4PF XX.Xm
<b>Mounting accessories</b>	
FA.RSC.ACC.002-01	COMMONSense - HEAT SINK - AISI303 Ø30,0 (M6) x74,5mm
FU.SEACMAG-01	Flat Magnetic Foot
FU.SEACMAG-02	Curved Magnetic Foot
FU.SEACMP1	Mounting pad
FU.RSC.ACC.001	<p>Configuration Interface (see DC.RSC.DAT.015)</p>

**The foot is a part of the resonant structure, please do not disassemble it!**

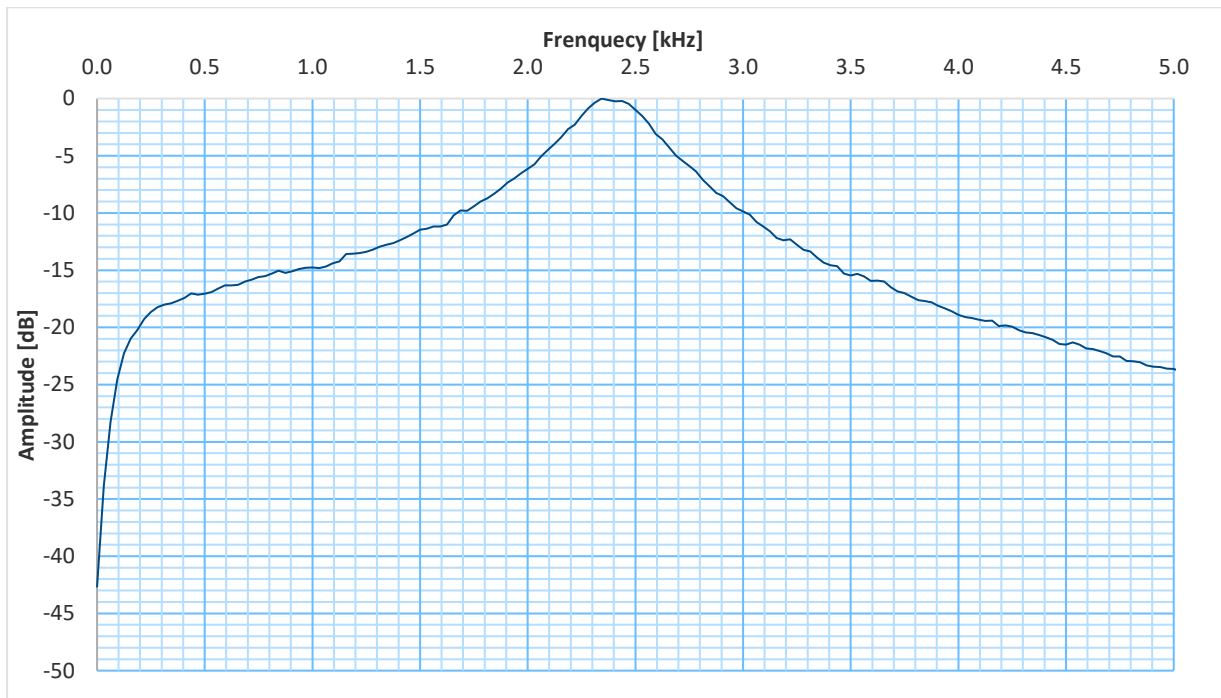
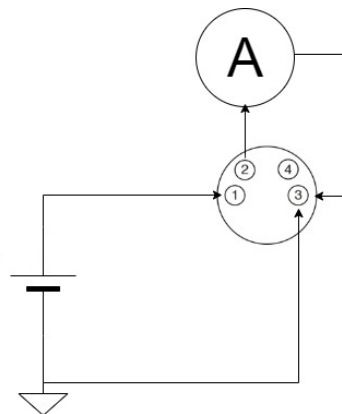
**Normalized heterodyned response curve (typical):****Wiring configuration:****Standalone****Output equation in static mode:**

- (1) Sensor signal [ $mV_{RMS}$ ] =  $\frac{\text{Current } [A_{DC} \text{ in mA}] \times 10 [\Omega]}{\text{linear Gain}}$
- (2) Sensor signal [ $dB\mu V_{RMS}$ ] =  $20 \times \text{Log}(\text{Current } [A_{DC} \text{ in mA}] \times 10 [\Omega]) - \text{Gain} [dB] + 60$
- (2') Sensor signal [ $dB\mu V_{RMS}$ ]  $\sim 0.81 \times \text{Current } [A_{DC} \text{ in mA}] + 91 - \text{Gain} [dB]$

In static mode, for convenience, SDT recommends expressing the sensor output in [ $dB\mu V_{RMS}$ ] using (2) or (2') since the output refers to variation in RMS. Please refer to the approximation of the logarithmic scale given in (2'), in case you cannot enter the logarithmic relationship in your acquisition system. Approximating the logarithmic scale in the retain measurement range introduces a maximum related inaccuracy of +/- 2 dB.

Gain [dB]	Linear Gain	Sensitivity [V]/[mA]	Offset [mA]	Optimal range [dBμV <sub>RMS</sub> ]
0	1	10	0	[92-106]
12	4	2.5	0	[80-94]
24	16	0.625	0	[68-82]
36	63	0.159	0	[56-70]
48	251	0.040	0	[44-58]
60	1000	0.001	0	[32-46]

Table 1: Sensitivities according to the gain

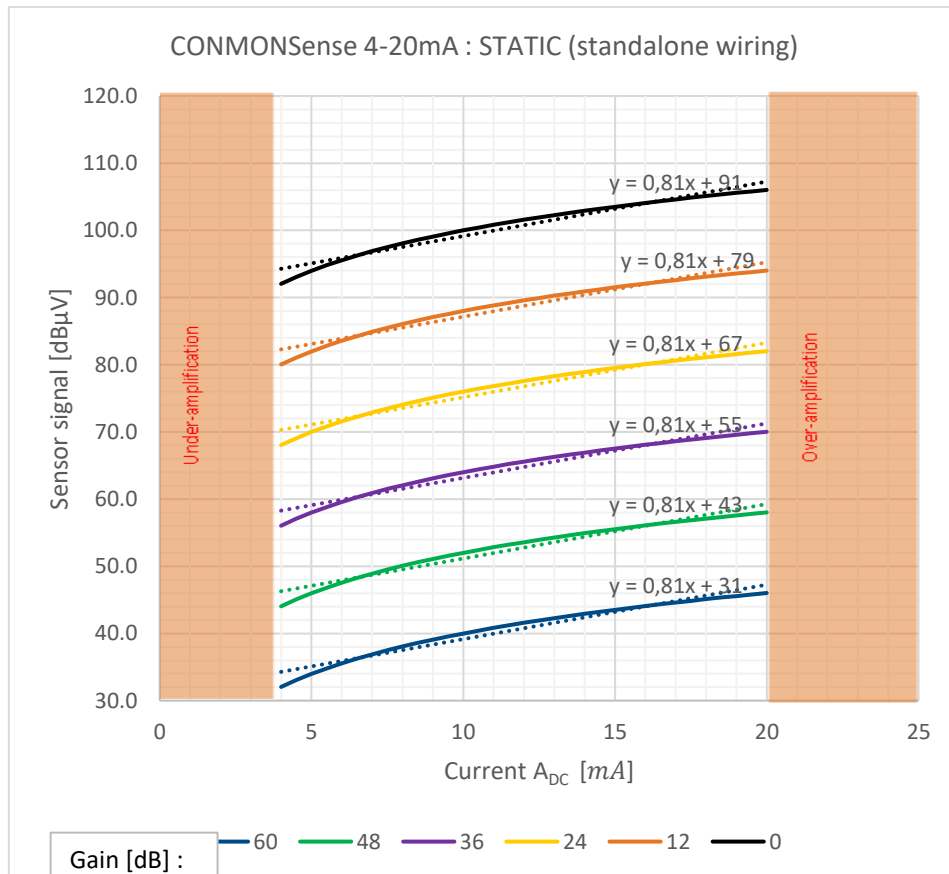

Figure 1: Sensor signal in dBμV vs Current, for each gain (standalone wiring)

Current A <sub>DC</sub> [in mA]	Gain [dB]					
	60	48	36	24	12	0
<4	Under-amplification					
4	32,0	44,0	56,0	68,0	80,0	92,0
5	34,0	46,0	58,0	70,0	82,0	94,0
6	35,6	47,6	59,6	71,6	83,6	95,6

7	36,9	48,9	60,9	72,9	84,9	96,9
8	38,1	50,1	62,1	74,1	86,1	98,1
9	39,1	51,1	63,1	75,1	87,1	99,1
10	40,0	52,0	64,0	76,0	88,0	100,0
11	40,8	52,8	64,8	76,8	88,8	100,8
12	41,6	53,6	65,6	77,6	89,6	101,6
13	42,3	54,3	66,3	78,3	90,3	102,3
14	42,9	54,9	66,9	78,9	90,9	102,9
15	43,5	55,5	67,5	79,5	91,5	103,5
16	44,1	56,1	68,1	80,1	92,1	104,1
17	44,6	56,6	68,6	80,6	92,6	104,6
18	45,1	57,1	69,1	81,1	93,1	105,1
19	45,6	57,6	69,6	81,6	93,6	105,6
20	46,0	58,0	70,0	82,0	94,0	106,0
>20	Over-amplification					

Table 2: Current / voltage equivalence table, in static mode

**Output equation in dynamic mode:**

- (3)  $Sensor\ signal\ [mV] = \frac{(current\ [A_{DC}\ in\ mA] - 12\ [A_{bias}]) \times 208.25\ [\Omega]}{linear\ Gain}$

In dynamic mode, SDT recommends expressing the sensor output in Voltage [mV].

Gain [dB]	Linear Gain	Sensitivity [V]/[mA]	Offset/A <sub>bias</sub> [mA]	Optimal range [mV]
0	1	208.25	12	[-1666 ; +1666]
12	4	52.06	12	[-418 ; +418]
24	16	13.02	12	[-105 ; +105]
36	63	3.31	12	[-26 ; +26]
48	251	0.83	12	[-6.6 ; +6.6]
60	1000	0.208	12	[-1.7 ; +1.7]

Table 3: Sensitivities according to the gain, in dynamic mode

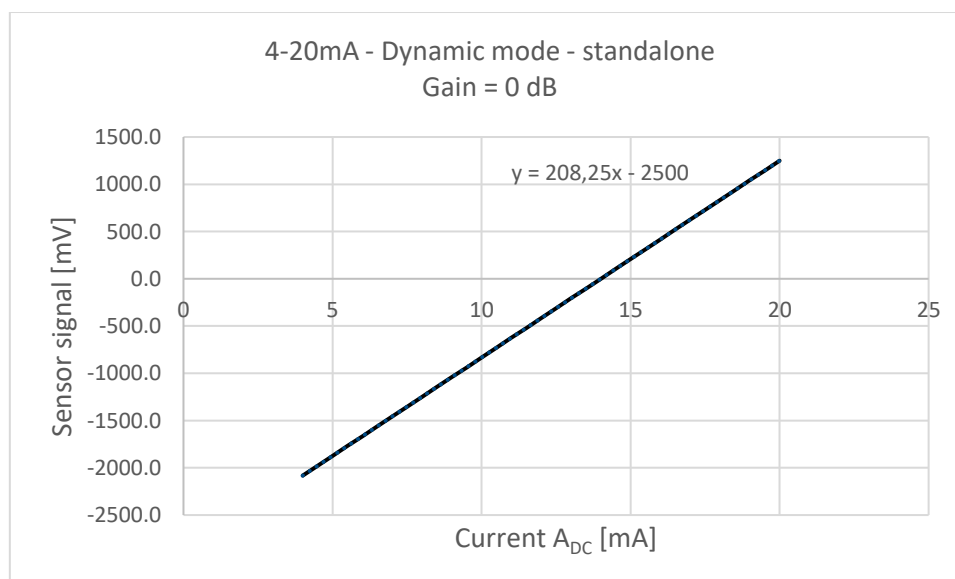

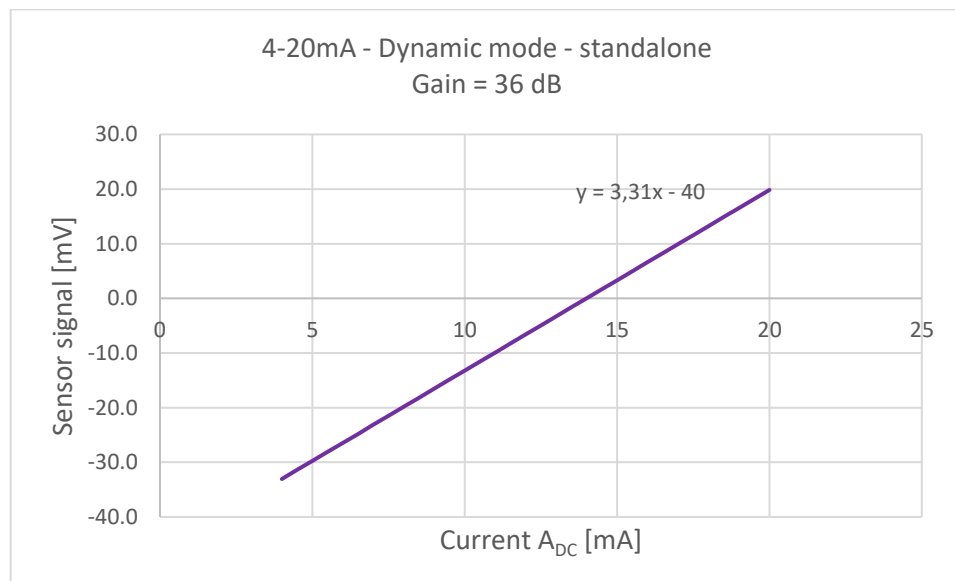
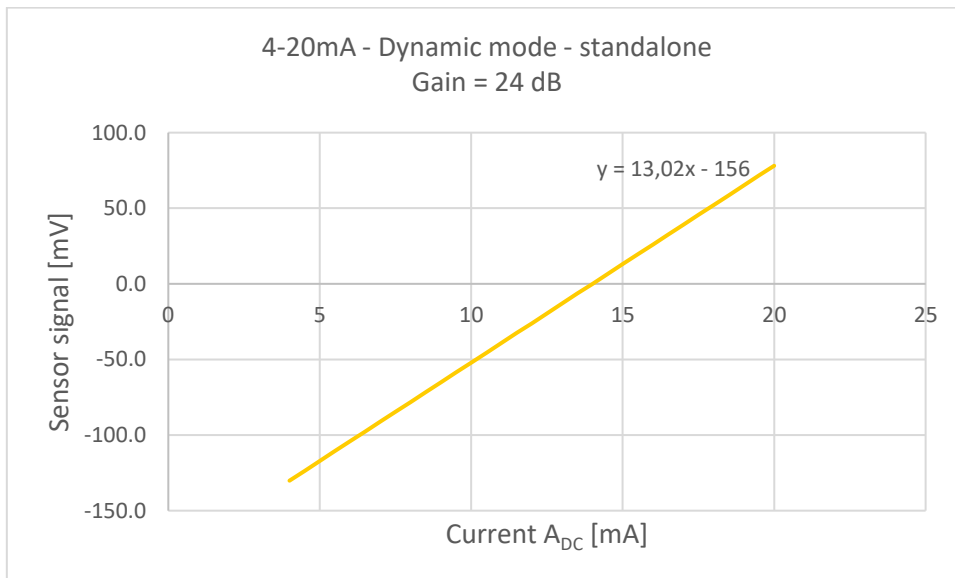
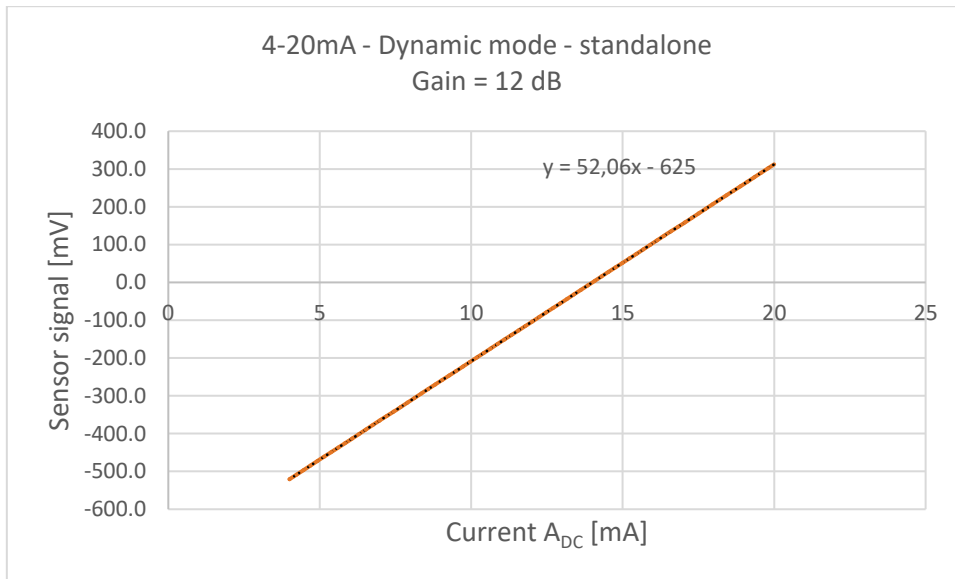



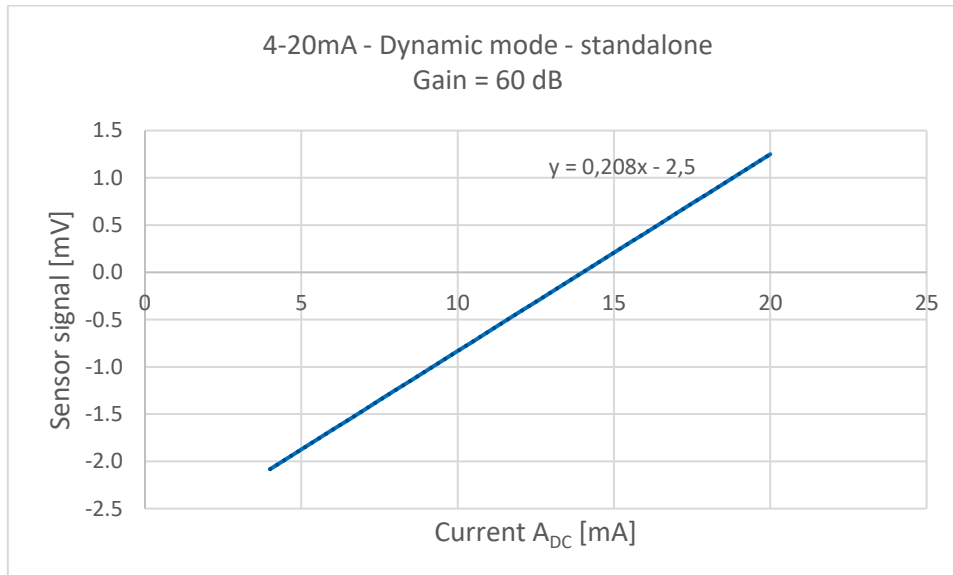
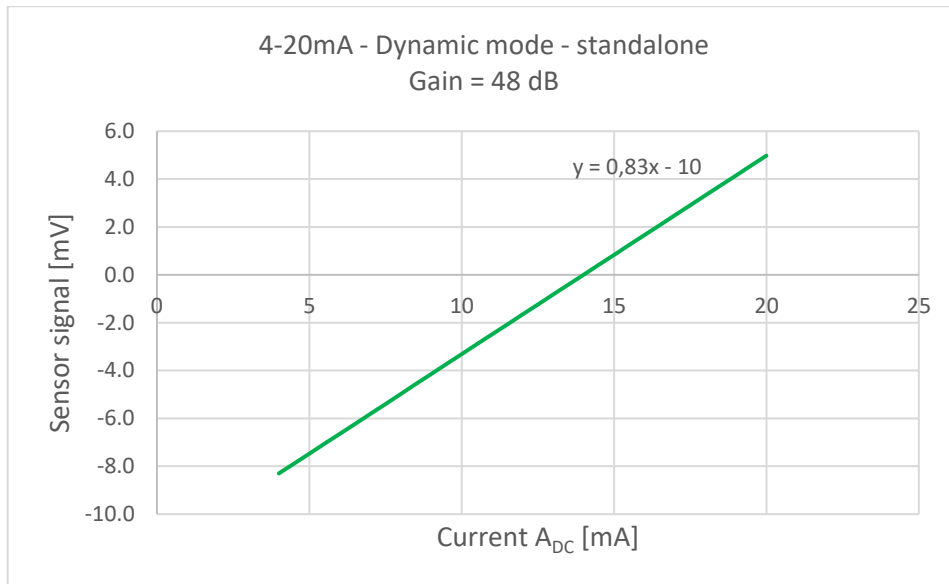

Current A <sub>DC</sub> [mA]	Gain [dB]					
	60	48	36	24	12	0
<4	Under-amplification					
4	-1,7	-6,6	-26,4	-105,1	-418,5	-1666,0
5	-1,5	-5,8	-23,1	-92,0	-366,2	-1457,8
6	-1,2	-5,0	-19,8	-78,8	-313,9	-1249,5
7	-1,0	-4,1	-16,5	-65,7	-261,6	-1041,3
8	-0,8	-3,3	-13,2	-52,6	-209,2	-833,0
9	-0,6	-2,5	-9,9	-39,4	-156,9	-624,8
10	-0,4	-1,7	-6,6	-26,3	-104,6	-416,5
11	-0,2	-0,8	-3,3	-13,1	-52,3	-208,3
12	0	0	0	0	0	0
13	0,2	0,8	3,3	13,1	52,3	208,3
14	0,4	1,7	6,6	26,3	104,6	416,5
15	0,6	2,5	9,9	39,4	156,9	624,8

16	0,8	3,3	13,2	52,6	209,2	833,0
17	1,0	4,1	16,5	65,7	261,6	1041,3
18	1,2	5,0	19,8	78,8	313,9	1249,5
19	1,5	5,8	23,1	92,0	366,2	1457,8
20	1,7	6,6	26,4	105,1	418,5	1666,0
>20	Over-amplification					

Table 4: Current / voltage equivalence table, in dynamic mode

### Loop powered

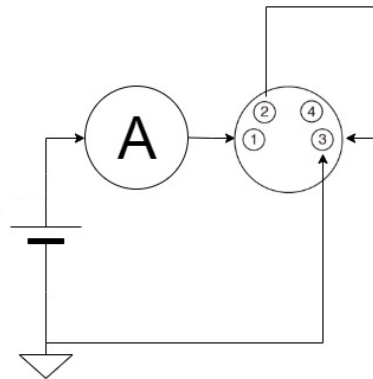

### Output equation in static mode:

- (4) Sensor signal [ $mV_{RMS}$ ] =  $\frac{(Current [A_{DC} \text{ in mA}] - 2[A_{bias}]) * 10 [\Omega]}{\text{linear Gain}}$
- (5) Sensor signal [ $dB\mu V_{RMS}$ ] =  $20 \times \text{Log}((Current [A_{DC} \text{ in mA}] - 2[A_{bias}]) \times 10 [\Omega]) - \text{Gain [dB]} + 60$
- (5') Sensor signal [ $dB\mu V_{RMS}$ ]  $\sim 1.04 \times Current [A_{DC} \text{ in mA}] + 86 - \text{Gain [dB]}$

In static mode, for convenience, SDT recommends expressing the sensor output in [ $dB\mu V_{RMS}$ ] using (5) or (5'), since the output refers to variation in RMS. Please refer to the approximation of the logarithmic scale given in (6') in case you cannot enter the logarithmic relationship in your acquisition system. Approximating the logarithmic scale in the measurement range introduces a maximum related inaccuracy of +/- 2 dB.

Gain [dB]	Linear Gain	Sensitivity [V]/[mA]	Offset [mA]	Optimal range [ $dB\mu V_{RMS}$ ]
0	1	10	2	[86-105]
12	4	2.5	2	[74-93]
24	16	0.625	2	[62-81]
36	63	0.159	2	[50-69]
48	251	0.040	2	[38-57]
60	1000	0.001	2	[26-45]

Table 5: Sensitivities according to the gain, in static mode (loop powered)

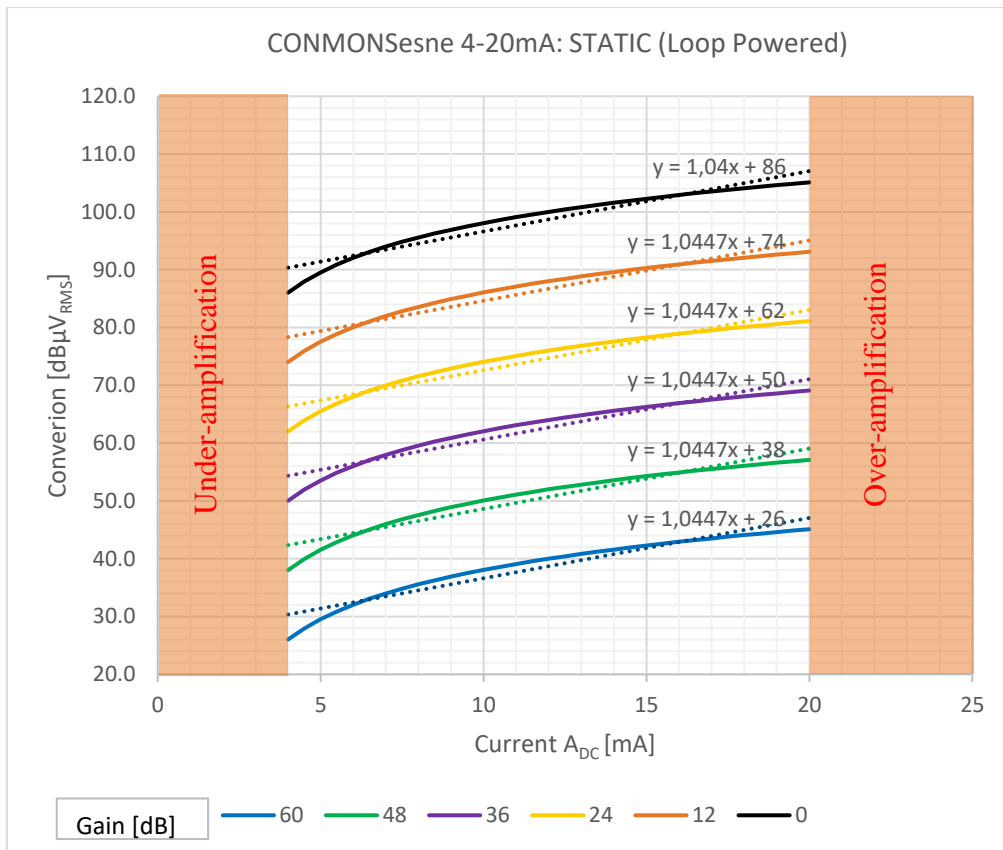

Figure 2: Sensor signal in dBµV vs Current, for each gain (loop powered)

Current A <sub>DC</sub> [mA]	Gain [dB]					
	60	48	36	24	12	0
<4	Under-amplification					
4	26,0	38,0	50,0	62,0	74,0	86,0
5	29,5	41,5	53,5	65,5	77,5	89,5
6	32,0	44,0	56,0	68,0	80,0	92,0
7	34,0	46,0	58,0	70,0	82,0	94,0
8	35,6	47,6	59,6	71,6	83,6	95,6
9	36,9	48,9	60,9	72,9	84,9	96,9
10	38,1	50,1	62,1	74,1	86,1	98,1
11	39,1	51,1	63,1	75,1	87,1	99,1
12	40,0	52,0	64,0	76,0	88,0	100,0
13	40,8	52,8	64,8	76,8	88,8	100,8
14	41,6	53,6	65,6	77,6	89,6	101,6
15	42,3	54,3	66,3	78,3	90,3	102,3
16	42,9	54,9	66,9	78,9	90,9	102,9
17	43,5	55,5	67,5	79,5	91,5	103,5
18	44,1	56,1	68,1	80,1	92,1	104,1
19	44,6	56,6	68,6	80,6	92,6	104,6
20	45,1	57,1	69,1	81,1	93,1	105,1
>20	Over-amplification					

Table 6: Current / voltage equivalence table, in static mode (loop powered)

**Output equation in dynamic mode:**

- (6)  $Sensor\ signal\ [mV] = \frac{(current\ [A_{AC}\ in\ mA] - 14\ [A_{bias}]) \times 208.25\ [\Omega]}{linear\ Gain}$

In dynamic mode, SDT recommends expressing the sensor output in Voltage [mV] using expression (6).

Gain [dB]	Linear Gain	Sensitivity [V]/[mA]	Offset/A <sub>bias</sub> [mA]	Optimal range [mV]
0	1	208.25	14	[-2082 ; +2082]
12	4	52.06	14	[-521 ; +521]
24	16	13.02	14	[-130 ; +130]
36	63	3.31	14	[-33 ; +33]
48	251	0.83	14	[-8.3 ; +8.3]
60	1000	0.208	14	[-2.1 ; +2.1]

Table 7: Sensitivities according to the gain, in dynamic mode (loop powered)

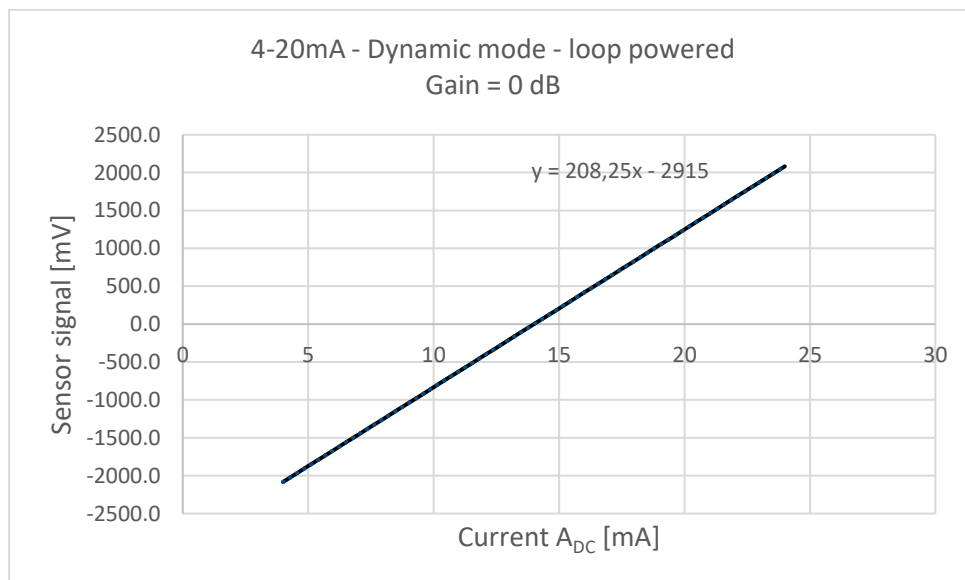

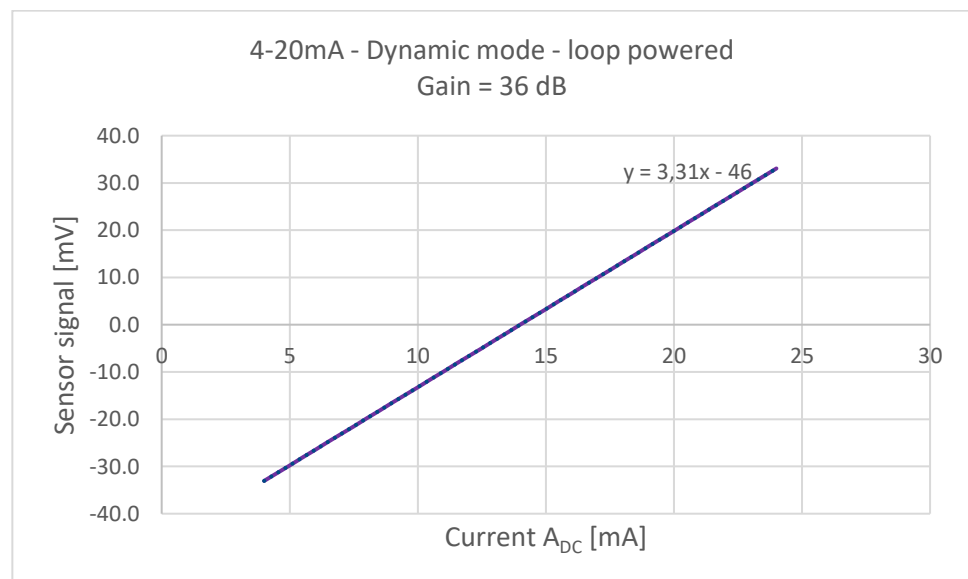
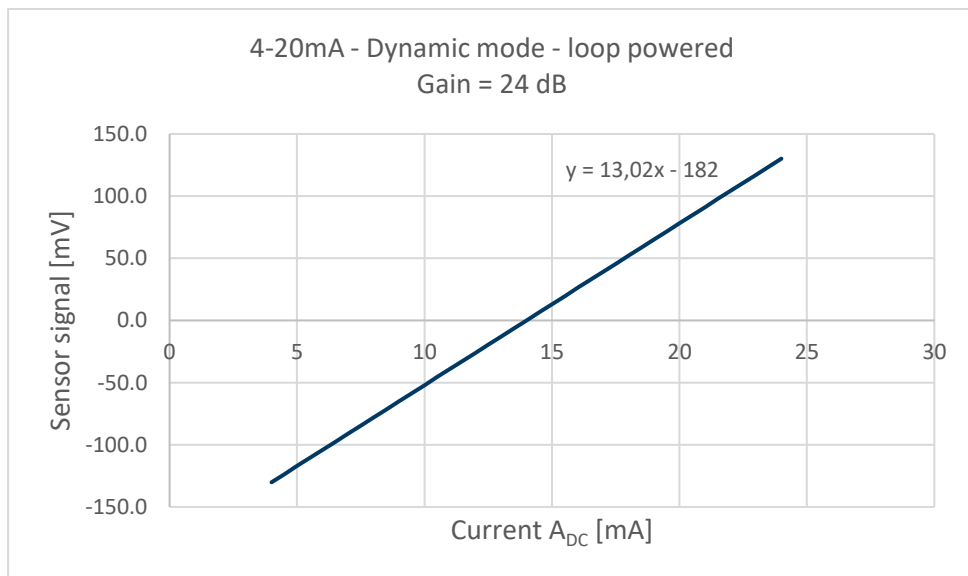
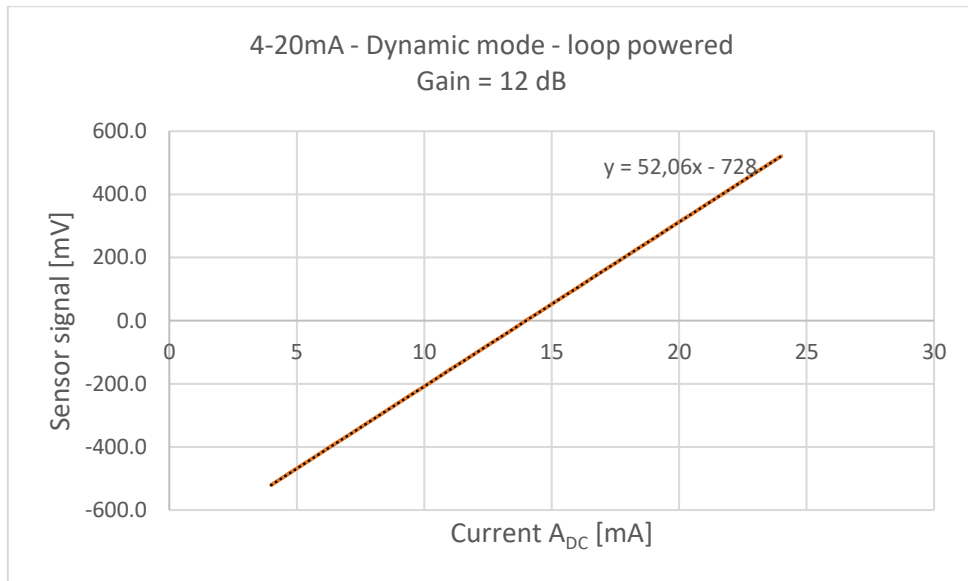

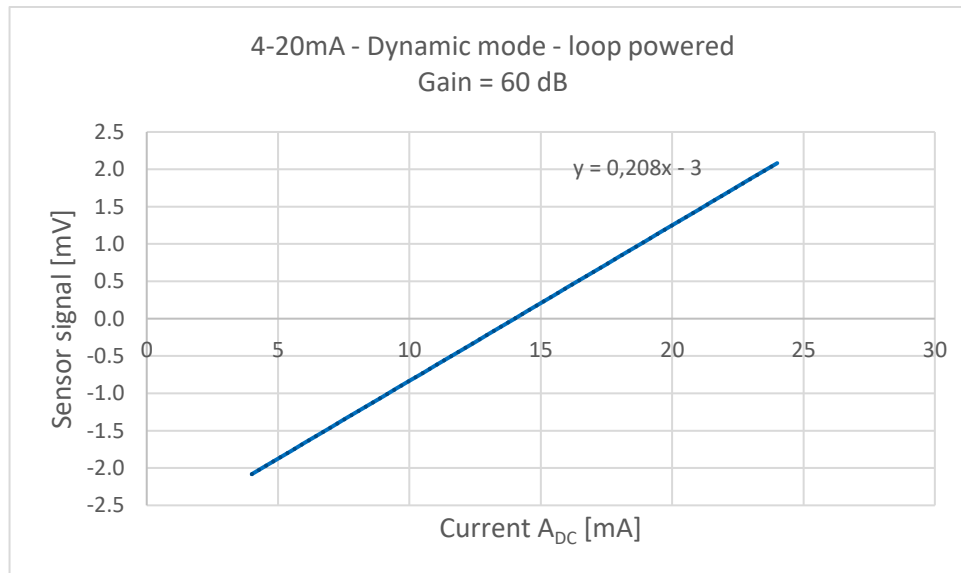
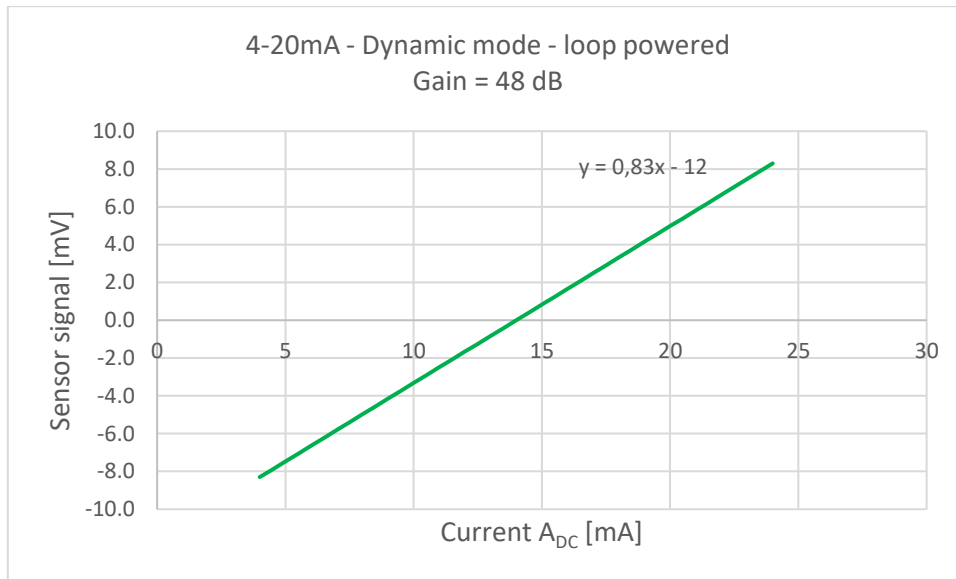

Current $A_{DC}$ [mA]	Amplification [dB]					
	60	48	36	24	12	0
Sensor signal [mV]						
<4	Under-amplification					
4	-2,1	-8,3	-33,1	-130,2	-520,6	-2082,5
5	-1,9	-7,5	-29,8	-117,1	-468,6	-1874,3
6	-1,7	-6,6	-26,4	-104,1	-416,5	-1666,0
7	-1,5	-5,8	-23,1	-91,1	-364,4	-1457,8
8	-1,2	-5,0	-19,8	-78,1	-312,4	-1249,5
9	-1,0	-4,1	-16,5	-65,1	-260,3	-1041,3
10	-0,8	-3,3	-13,2	-52,1	-208,3	-833,0
11	-0,6	-2,5	-9,9	-39,0	-156,2	-624,8
12	-0,4	-1,7	-6,6	-26,0	-104,1	-416,5
13	-0,2	-0,8	-3,3	-13,0	-52,1	-208,3
14	0,0	0,0	0,0	0,0	0,0	0,0
15	0,2	0,8	3,3	13,0	52,1	208,3

16	0,4	1,7	6,6	26,0	104,1	416,5
17	0,6	2,5	9,9	39,0	156,2	624,8
18	0,8	3,3	13,2	52,1	208,3	833,0
19	1,0	4,1	16,5	65,1	260,3	1041,3
20	1,2	5,0	19,8	78,1	312,4	1249,5
21	1,5	5,8	23,1	91,1	364,4	1457,8
22	1,7	6,6	26,4	104,1	416,5	1666,0
23	1,9	7,5	29,8	117,1	468,6	1874,3
24	2,1	8,3	33,1	130,2	520,6	2082,5
>24			Over-amplification			

Table 8: Current / voltage equivalence table, in dynamic mode (loop powered)

### Voltage measurement :

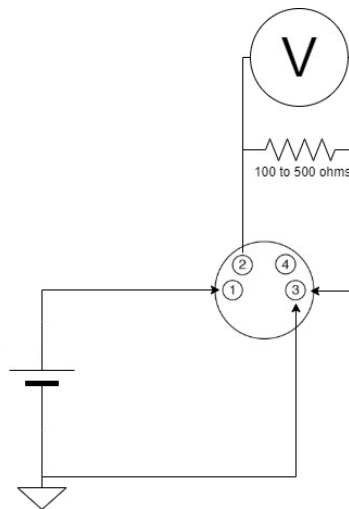

### Output equations:

- Static mode:

$$\text{Sensor signal } [V_{\text{RMS}}] = \frac{\left( \frac{\text{voltage } [V_{\text{DC}}]}{\text{resistor } [\Omega]} \right) * 10 [\Omega]}{\text{linear Gain}}$$

- Dynamic mode:

$$\text{Sensor signal } [V_{\text{AC}}] = \frac{\left( \frac{\text{voltage } [V_{\text{AC}}]}{\text{resistor } [\Omega]} - 0.012 [A_{\text{bias in A}}] \right) * 208.25 [\Omega]}{\text{linear Gain}}$$

### Communication:

#### Using the Configuration interface:

Gain and mode can be changed from a PC using the SDT accessory **FU.RSC.ACC.001**, in a simple way.

-**Download** then **install** the required SDT COMMONSENSE tool (compatible windows) at:

<https://sdtultrasound.com/support/software/>

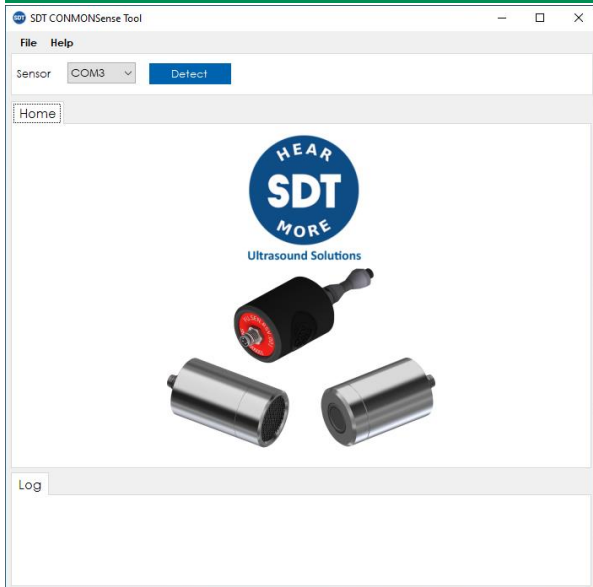

-**Connect** the sensor and the PC to the configuration interface using the provided cables.

-**Read & Edit** the sensor settings

#### Digital output mode

Gain and mode can be selected by generating pulses on the communication line.

The default state of the line is +VDD (pulled up internally with a 10 [kΩ] resistor) and a pulse consists of pulling the line down for at least 1 [ms] then releasing the line.

After the first pulse is initiated a 5 [s] internal timer is started. When the 5 [s] timeout occurs, the sensor counts how many pulses it received during this time-lapse:

- 1 pulse: increase the gain by 12 [dB] (has no effect if the gain is already at 60 [dB]);
- 2 pulses: decrease the gain by 12 [dB] (has no effect if the gain is already at 0 [dB]);
- 3 pulses: change the mode (switch between static and dynamic mode);
- 4 pulses: initialize the sensor in dynamic mode with a gain of 60 [dB] (factory reset);



After any modification, data are saved inside a non-volatile memory and are restored on sensor power on.

### Example

- Change the output mode (generate 3 pulses under 5 [s]).

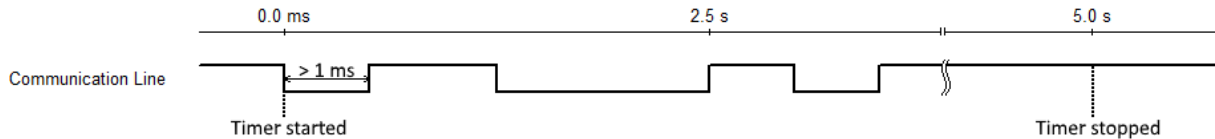

### Serial mode

The communication line can also be used for a serial communication allowing advanced features. The protocol used is UART 9600-8-E-1 (9600 bauds, 8 data bits, 1 even parity bit, 1 stop bit). The user can write data to the sensor and read them back:

- 1) The serial communication is initialized by the user by sending the header byte <AAh>.
- 2) The second byte is the device address or the generic address (<00h>). The sensor will only answer to its specific address or to the generic address.
- 3) The third byte is the memory address (see below) that the user wants to write or to read.
- 4) The fourth byte is the operation: <00h> for a write operation; <01h> for a read operation.
- 5)
  - a) During a write, the fifth byte is sent by the user with the data that needs to be written.
  - b) During a read, the fifth byte is sent by the user and contain the one-byte checksum.
- 6)
  - c) During a write, the sixth byte is sent by the user and contain the one-byte checksum.
  - d) During a read, the sixth byte is sent by the sensor containing the value of the memory address.

The one-byte checksum is the LSB (least signification byte) from the addition of all bytes sent.

After any modification, data are saved inside a non-volatile memory and are restored on sensor power on.

### Memory address

00	Sensor specific address (R/W)	range 0 to 255
01	Sensor gain (R/W)	range 0 to 60 with a step of 12
02	Sensor mode (R/W)	1 for static mode; 2 for dynamic mode
03	Temperature (R)	8bits integer temperature value
04	Temperature (R)	32bits float temperature value byte 1 (LSB)
05	Temperature (R)	32bits float temperature value byte 2
06	Temperature (R)	32bits float number temperature value byte 3

07	Temperature (R) (MSB)	32bits float number temperature value byte 4
08	Firmware version (R)	32bits integer firmware version value byte 1 (LSB)
09	Firmware version (R)	32bits integer firmware version value byte 2
10	Firmware version (R)	32bits integer firmware version value byte 3
11	Firmware version (R) (MSB)	32bits integer firmware version value byte 4

### Examples

- e) Write a new specific device address, <11h> to the sensor:

*User: <AAh 00h 00h 00h 11h BBh>*  
(Checksum is AAh + 11h = BBh)

- f) Read the sensor gain (assuming the gain is set at 48 [dB] and the device specific address is set to <11h>):

*User: <AAh 11h 01h 01h BDh>*  
*Sensor: <30h>*  
(Checksum is AAh + 11h + 01h + 01h = BDh)

*The information herein is believed to be accurate to the best of our knowledge.  
Due to continuous research and development, specifications are subject to change without prior notice.*

12	CMA 27/02/2023	Operating T°+ harmonization	RGO
11	CMA 08/02/2022	Configuration interface	RGO
10	CMA 26/11/2021	Graphs/tables and tests/approvals	CGI
09	CMA 20/04/2021	Max cable length	RGO
08	CMA 10/11/2020	Cable length under brackets/ graphs / U-I conversion	RGO
07	CMA 05/11/2020	New info in table + factory reset	RGO
06	RGO 03/11/2020	Removed internal diagram	CMA
05	CGI 29/10/2020	No commas but dots	CGI
04	RGO 21/10/2020	Added serial number	CGI
<b>Revision</b>	<b>Writer</b>	<b>Nature of modification</b>	<b>Approved</b>