

Datasheet FU.SEN.RSC. 103 TRUE 4-20mA Airborne Sensor IP 40

RED - S/N 575 YY XXXX

General description:

RSC.103 are ultrasound current output sensors crafted for integration with industrial standard measurement systems, including PLC, DCS, and DAQ system.

Designed for enduring performance in the most demanding environments, RSC TRUE 4-20 mA airborne sensors excel in applications such as leak detection and electrical monitoring. Sensitive to airborne ultrasound sources, RSC TRUE 4-20 mA provides the overall ultrasound level (RMS), captured in the ultrasound band-pass frequency



Main Features:



- **4-20 mA output (DC coupling):** Seamlessly correlates with ultrasound RMS indicator, facilitating easy integration into existing monitoring systems without the need for complex conversions.
- **Built-in analog circuit “Ultrasound resonant signal to RMS”:** Guarantees accurate analog signal processing.
- **Hardware calibration** for consistent and reliable measurements.
- **Plug & Play functionality:** Ensures easy installation and immediate operation across a wide measurement range, making it ideal for a variety of industrial settings.
- **Available in IP 65 (RSC.102) or IP 40.**

Top view M8-M pinout (IEC 60947-5-2 compliant):

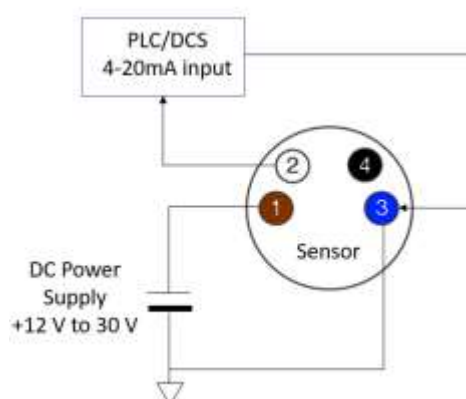
- 1 = POWER SUPPLY (Brown)
- 2 = OUTPUT CURRENT (White)
- 3 = GROUND (Blue)
- 4 = COM -should be left unconnected if not used – (Black)

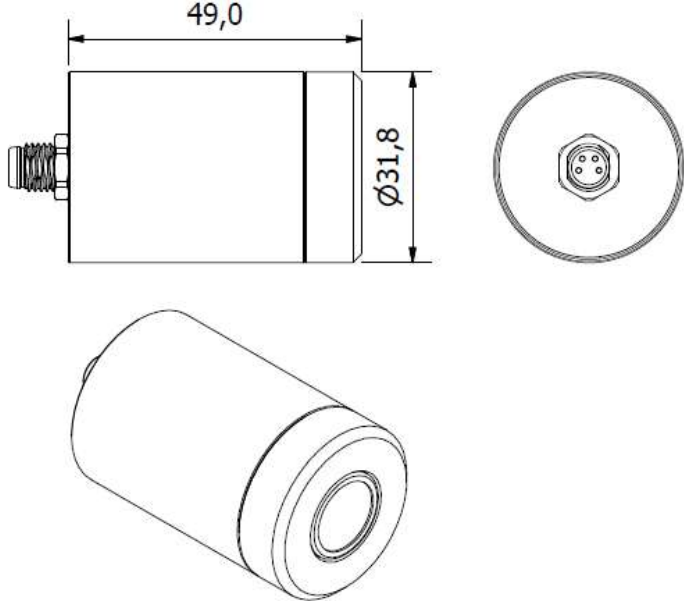

Technical specifications:

General specifications	
Dimensions [mm]	
Description	COMMONSense RSC US TRUE 4-20mA M8 4PM – AIRBORNE SENSOR OPEN IP 40
Model	FU.SEN.RSC.103 (SN 575 YY NNNN)
Type of transducer	Piezoelectric ceramic
Analog output	4-20 mA DC
Materials	Housing: Stainless steel Connector plate: Aluminum
Mass	130 [Gram] / 4.6 [Oz]
IP rating	IP 40, exists in IP 65 (see RSC.102) <i>The IP rating of the sensor impacts its effective sensitivity and directivity. Capturing certain sources may become challenging due to attenuation, especially with IP 65</i>
Tests/approvals 	compliant with the essential requirements of Electromagnetic Compatibility (EMC) Directive 2014/30/EU
Installation	
Power supply	12 [V] to 30 [V] DC
Maximum consumption	750 [mW]
Operating temperature	-20 [°C] to +70 [°C] / -4 [°F] to +158 [°F], non-condensing environment
Storage temperature	-20 [°C] to +70 [°C] / -4 [°F] to +158 [°F], non-condensing environment
Recommended max cable length	30 [m] / 100 [feet] <i>EMC tests not guaranteed beyond</i> Using 4-20 mA analog outputs provides good immunity to environmental disturbances, ensuring reliable signal transmission over longer distances
Connector	M8 - 4 pin – Male

Mounting options	See section optional accessories
Ultrasound signal (Typical)	
Resonant frequency	$F_{res} = 40 \text{ [kHz]} \pm 1 \text{ [kHz]} @ 20 \text{ }^\circ\text{C}$
Band-pass frequency	$\pm 2 \text{ [kHz]}$ centered on F_{res}
Detector type	RMS@1second
startup time	$\sim 5 \text{ [s]}$
Output range	4 to 20 [mA]
Measuring range	20 to 100 [dB μV_{RMS}]
Conversion function	0.2 [mA/dB μV_{RMS}], offset = 0 [dB μV_{RMS}]
Resolution	0.5 [dB μV_{RMS}]
Optional accessories	
Cables with Straight M8 Connector – PUR RAL7021 -25°C.+90°C IP65 – STRAIGHT SHIELDED	
FU.RSC.CABL.01.015-1	SENSOR-/ACTOR CABLE M8 4PF <> FREE END 1.5m
FU.RSC.CABL.01.030-1	SENSOR-/ACTOR CABLE M8 4PF <> FREE END 3.0m
FU.RSC.CABL.01.050-1	SENSOR-/ACTOR CABLE M8 4PF <> FREE END 5.0m
FU.RSC.CABL.01.100-1	SENSOR-/ACTOR CABLE M8 4PF <> FREE END 10.0m
FU.RSC.CABL.01.200-1	SENSOR-/ACTOR CABLE M8 4PF <> FREE END 20.0m
FU.RSC.CABL.01.XXX-1	SENSOR-/ACTOR CABLE M8 4PF <> FREE END XX.Xm
Cables with 90° M8 Connector – PUR RAL7021 -25°C.+90°C IP65 – STRAIGHT SHIELDED	
FU.RSC.CABL.02.015-1	SENSOR-/ACTOR CABLE M8 4PF 90° <> FREE END 1.5m
FU.RSC.CABL.02.030-1	SENSOR-/ACTOR CABLE M8 4PF 90° <> FREE END 3.0m
FU.RSC.CABL.02.050-1	SENSOR-/ACTOR CABLE M8 4PF 90° <> FREE END 5.0m
FU.RSC.CABL.02.100-1	SENSOR-/ACTOR CABLE M8 4PF 90° <> FREE END 10.0m
FU.RSC.CABL.02.200-1	SENSOR-/ACTOR CABLE M8 4PF 90° <> FREE END 20.0m
FU.RSC.CABL.02.XXX-1	SENSOR-/ACTOR CABLE M8 4PF 90° <> FREE END XX.Xm
Connector to complete assembly	
SICOCA-M8-4MSS-01	CABLE CONNECTOR M8 4PM SHIELDED STRAIGHT A-KEY w/SCREW TERMINAL
SICOCA-M8-4FSS-01	CABLE CONNECTOR M8 4PF SHIELDED STRAIGHT A-KEY w/SCREW TERMINAL
Cables with straight M8 connector 4PM <> M8 4PF – PUR BLACK -25°C.+80°C IP65 – STRAIGHT SHIELDED	
FU.RSC.CABL.05.015-1	SENSOR-/ACTOR CABLE M8 4PM <> M8 4PF 1.5m
FU.RSC.CABL.05.030-1	SENSOR-/ACTOR CABLE M8 4PM <> M8 4PF 3.0m
FU.RSC.CABL.05.050-1	SENSOR-/ACTOR CABLE M8 4PM <> M8 4PF 5.0m
FU.RSC.CABL.05.100-1	SENSOR-/ACTOR CABLE M8 4PM <> M8 4PF 10m
FU.RSC.CABL.05.200-1	SENSOR-/ACTOR CABLE M8 4PM <> M8 4PF 20m
FU.RSC.CABL.05.XXX-1	SENSOR-/ACTOR CABLE M8 4PM <> M8 4PF XX.Xm
Mounting accessories	
FA.RSC.ACC.001-01	4-20mA Heterodyne Mounting Accessories/Brackets

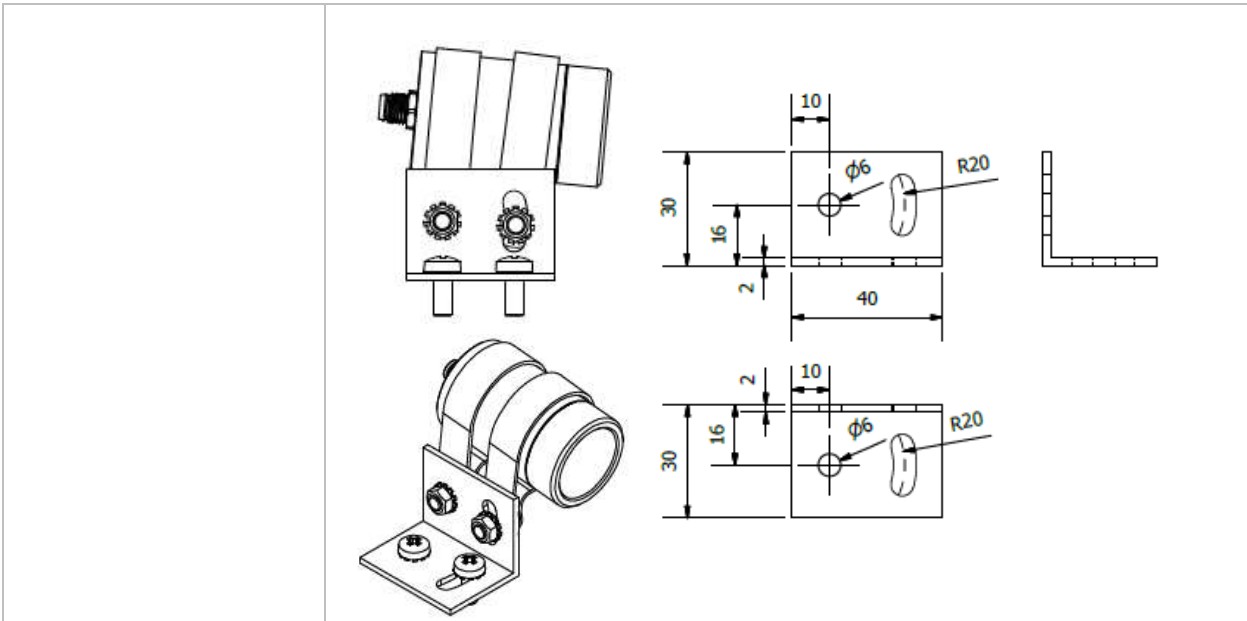

Configuration

By pulling (and holding) the communication line high (VDD – Power supply) or by keeping it floating (not connected), the analog output mirrors ultrasound RMS readings. The sensor signal range is 20 [dB_{μV RMS}] (4 mA) to 100 [dB_{μV RMS}] (20 mA). The output relationship is defined as follows:

- $Sensor\ signal\ [dB\mu V_{RMS}] \approx \frac{Measured\ current\ [mA]}{Sensitivity}$
- Conversion function:
 - 0.2 mA/dB_{μV}_{RMS}
 - offset = 0
- Resolution: 0.5 dB_{μV}_{RMS}

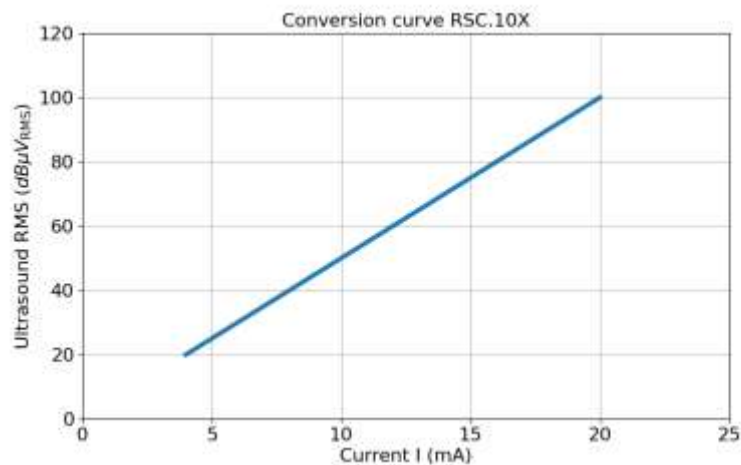

Note: Quiet environments below 20[dB_{μV RMS}] are not quantifiable by these sensors. Measuring 4 mA indicates that the surrounding environment is below or equal to 20[dB_{μV RMS}]. Similarly, noisy environments above 100[dB_{μV RMS}] are not quantifiable by these sensors.

Measuring 20 mA indicates that the surrounding environment is equal or above to $100[\text{dB}_{\mu\text{V}}_{\text{RMS}}]$.

Before any installation, it is important to determine if the typical ultrasound environment level at the expected installation point is within the specifications of the sensor. To do this, an SDT handheld device can be used.

Normalized heterodyned response curve (typical):

RSC.103 (tested under 10 Vrms@30 cm)

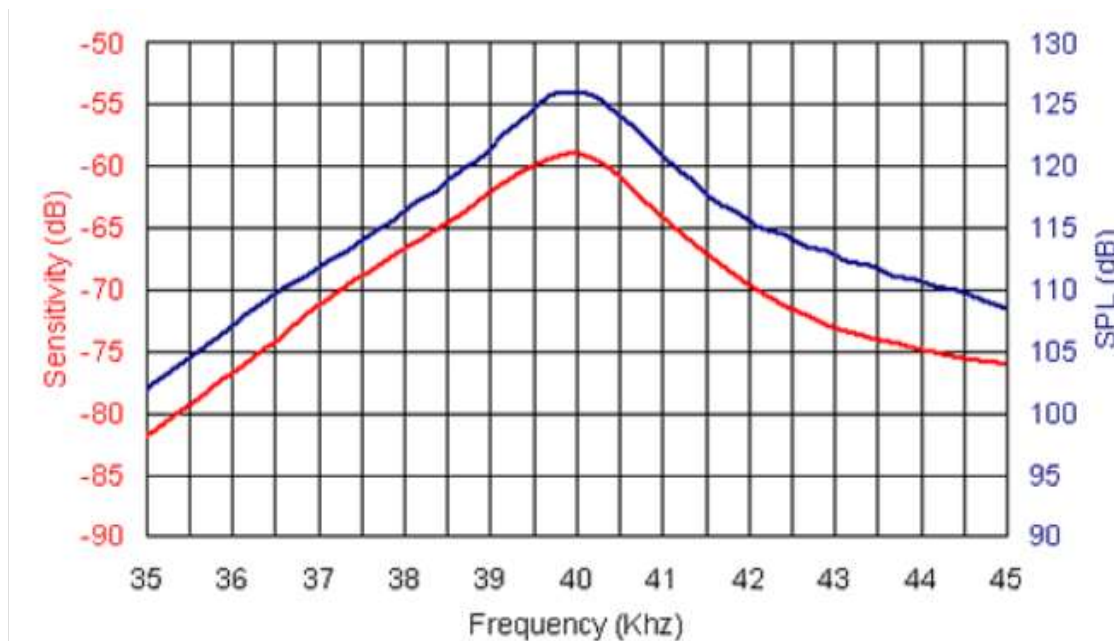

Beam angle:

RSC.103

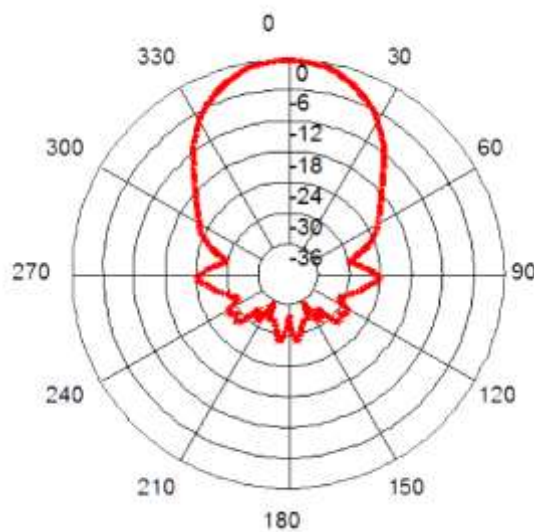

Safety recommendations:

To ensure safe and effective use of the sensor, please follow the safety recommendations below:

- Follow the recommendations mentioned in the datasheet
- Risk of injury when working in electrical environment.
- Adhere to all safety rules and regulations in your facility.
- Always wear proper protective clothing and use insulated tools when around electrical hazards.
- Installation should be carried out by qualified personnel, following the technical recommendations provided.
- Ensure that the material is properly mounted and secured before starting any measurements.
- Do not exceed the specified maximum supply voltage to avoid the risk of overheating or damage.
- Ensure that the power is disconnected before performing any adjustments or maintenance.
- Do not use the sensor in explosive atmospheres.
- The sensor is rated IP65 for dust and water jet protection. Do not immerse it and do not use it in conditions where it could be submerged.
- Avoid exposing the sensor to temperatures outside the specified operating range.
- A maximum recommended cable length of 30 meters/100 feet has been established based on EMC (Electromagnetic Compatibility) tests. Beyond these limits, the stability of the measurement is not guaranteed by SDT. The client is responsible for assessing the impact of their environment on the accuracy of the measurement.

Failure to follow these safety recommendations can result in injury, damage to the sensor or other equipment, and may affect the validity of the warranty. If in doubt regarding the installation, use, or maintenance of the sensor, please contact us.

04			
03			
02			
01	CMA 12/07/2024	Original version/Product release	RGO
Rev.	Writer	Nature of modification	Approved

*The information herein is believed to be accurate to the best of our knowledge.
Due to continuous research and development, specifications are subject to change without prior notice.*